

Fuselage framework from 2.4mm square (shown grey). Diagonal bracing 2.4 x 1.6mm.

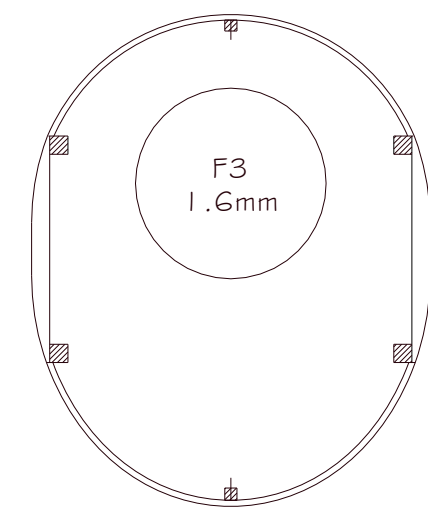

39mm dihedral under each wing tip

Note: This plan has **not** been test-flown yet, but is released free of charge for personal use.

Metric conversions:

- 0.8mm 1/32"
- 1.6mm 1/16"
- 2.4mm 3/32"
- 3.2mm 1/8"
- 4.8mm 3/16"
- 6.4mm 1/4"

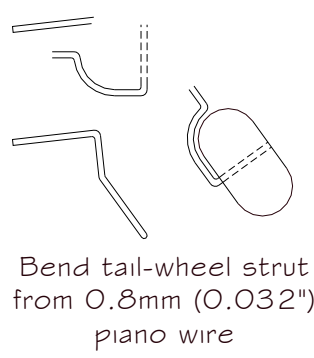

Yeoman Aviation Cropmaster 250			
A rubber powered flying scale model of a 1960's Australian cropduster			
Dimensions:	Prototype:	Model:	
Span:	10.36 m	610 mm	(18")
Length:	8.08 m	488 mm	(12.7")
Wing area:	16.50 m ²	5.70 dm ²	(43.5 in ²)
Weight:	1,542 kg	60 g	(1.0 oz)
Wing loading:	19.1 lb/ft ²	10.52 g/dm ²	(3.3 oz/ft ²)
Power:	250 hb	2 loops 3.2 x 600 mm	
Scale:		1 : 17	

Model designed by
Derek Buckmaster
February 2003
© D Buckmaster 2003

Fill this section with sheet to support landing gear mounts at W1, W2 and W3

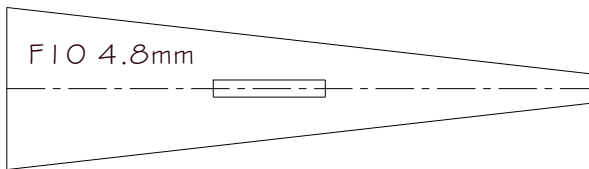
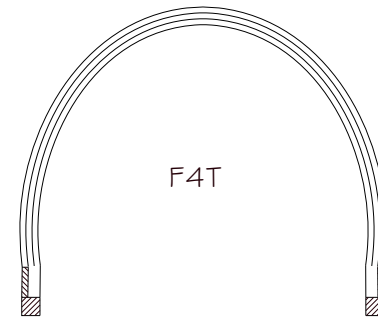

Wheel struts from 6.4mm hard sheet (2 off)



Landing gear struts:
Bend from 0.8mm diameter (0.032") piano wire.
2 required.

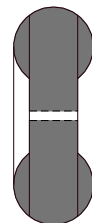
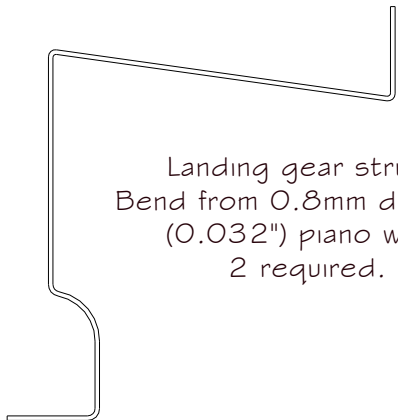

Wheels turned from sheet balsa.
Middle lamination 6.4mm, sides from 2.4mm.
1.6mm OD aluminium tubing for bearing.

Nose construction showing installation of Gizmo Geezer Precision Free Wheeler front end.

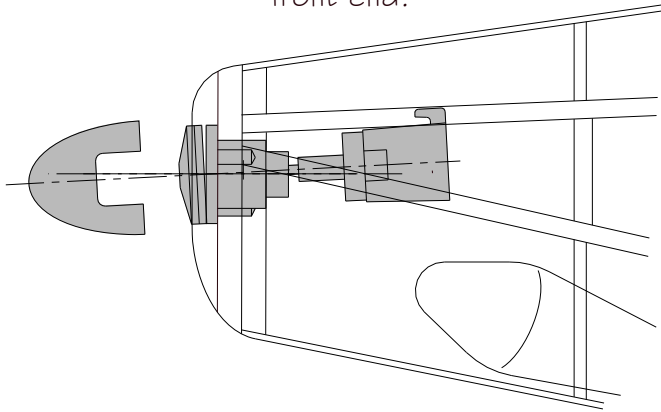

Make F1A from 2 laminations of 3.2mm sheet.
Drill a 13mm diameter hole in the front lamination.
Drill a 9mm diameter hole in the rear lamination.

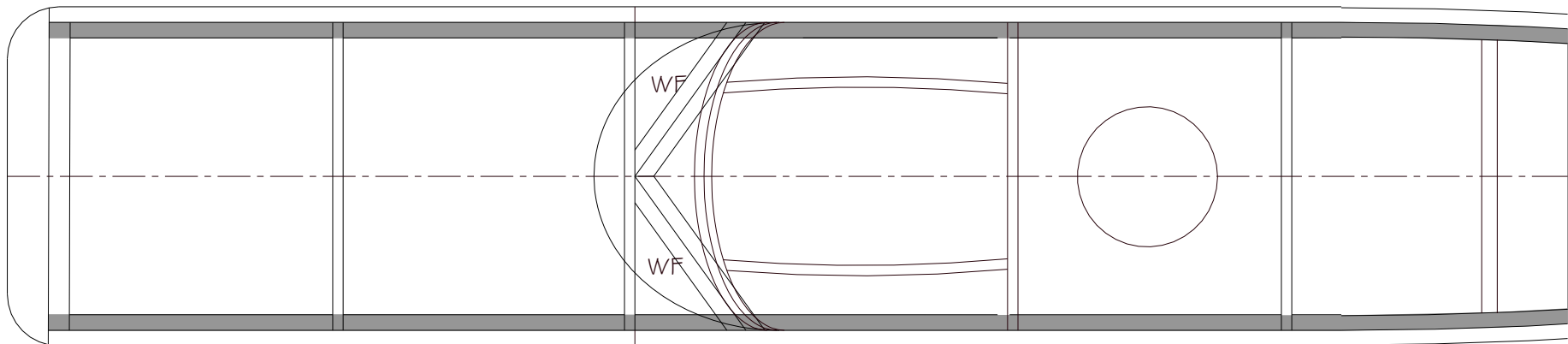
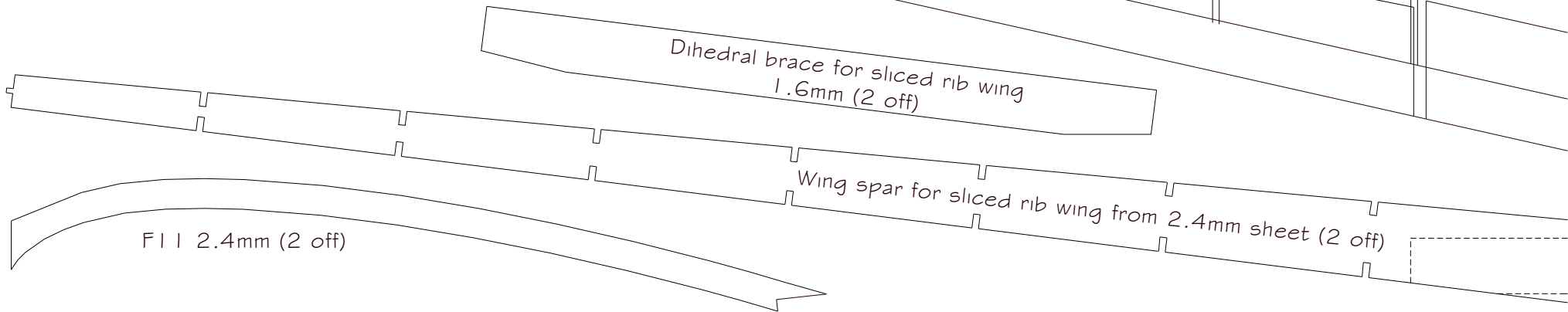
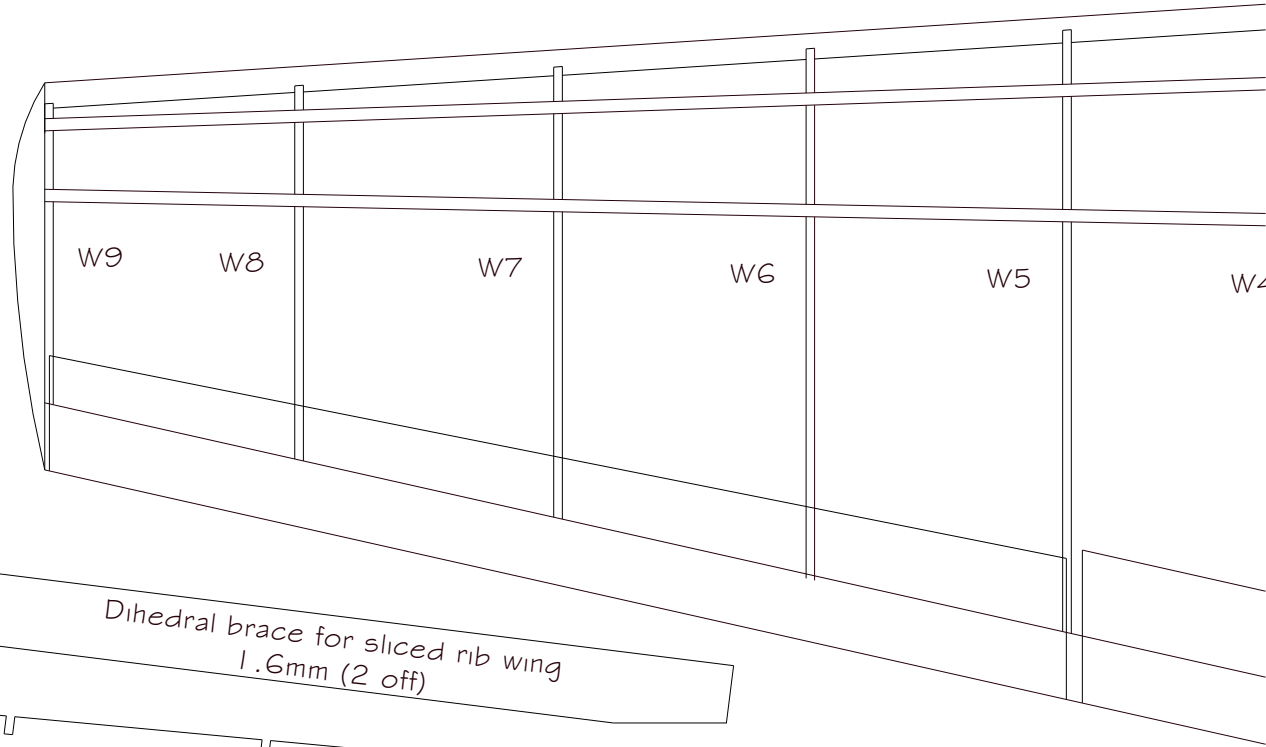

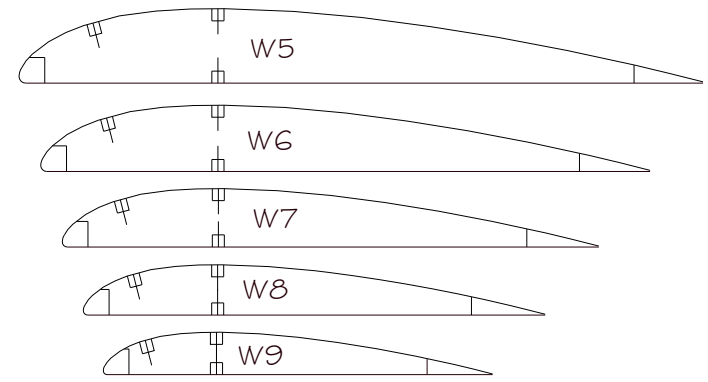
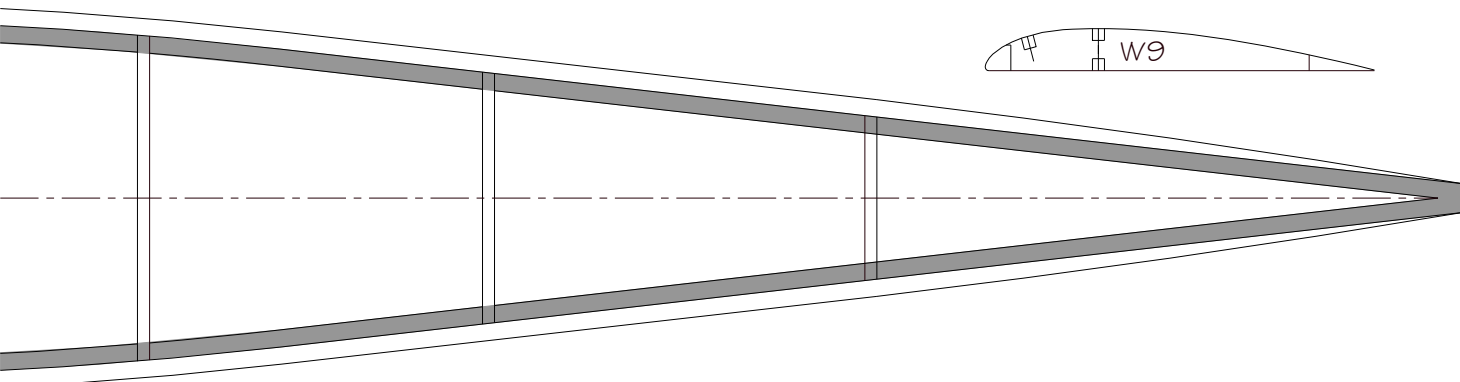
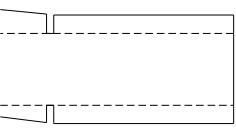
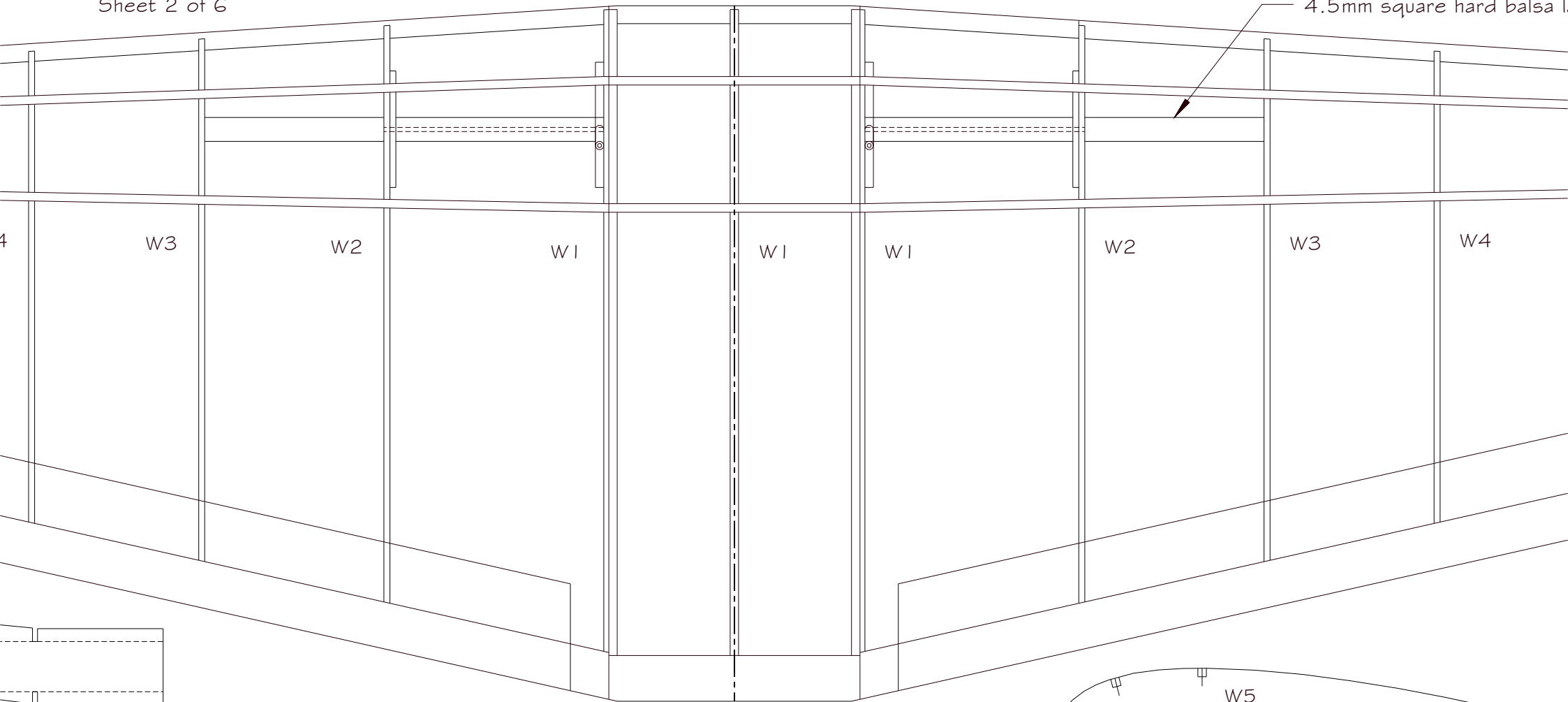

All wing ribs from 1.6mm sheet

