

McCauley D2A36C33/90M-2 propellor

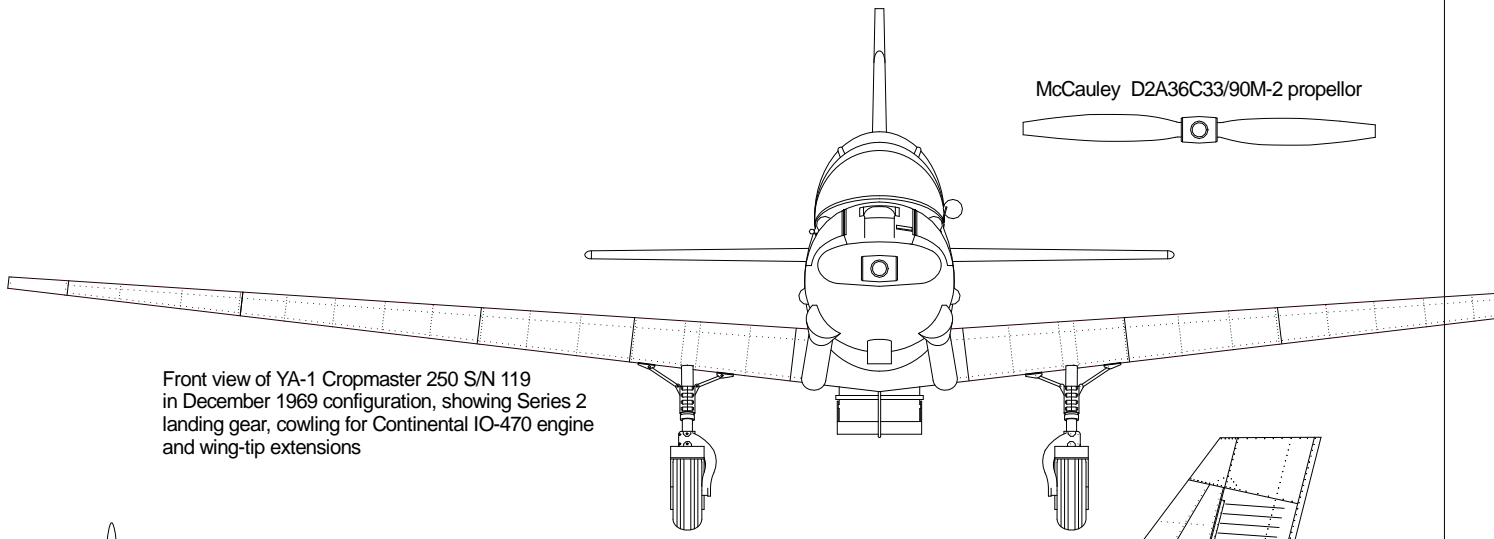

Front view of YA-1 Cropmaster 250 S/N 119 in December 1969 configuration, showing Series 2 landing gear, cowling for Continental IO-470 engine and wing-tip extensions

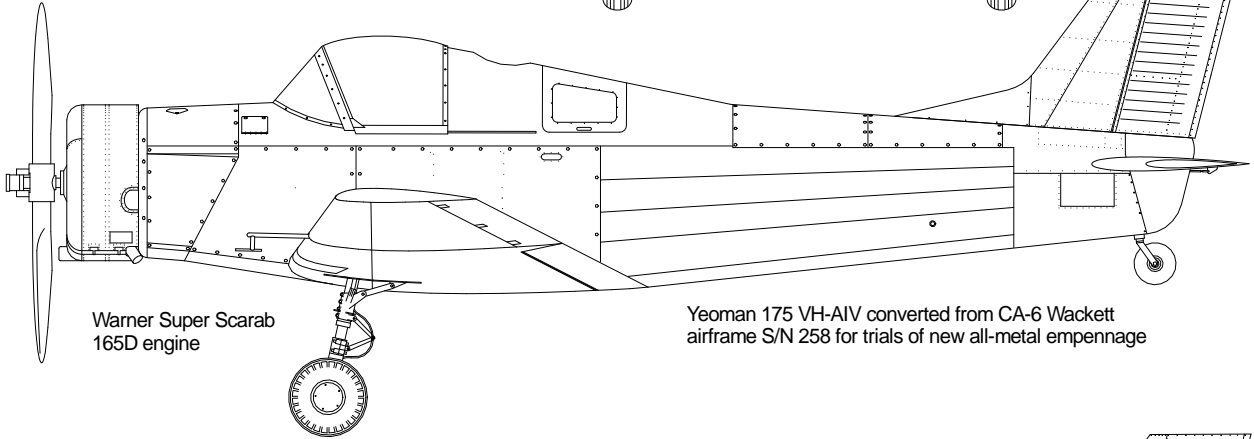

Warner Super Scarab 165D engine

Yeoman 175 VH-AIV converted from CA-6 Wackett airframe S/N 258 for trials of new all-metal empennage

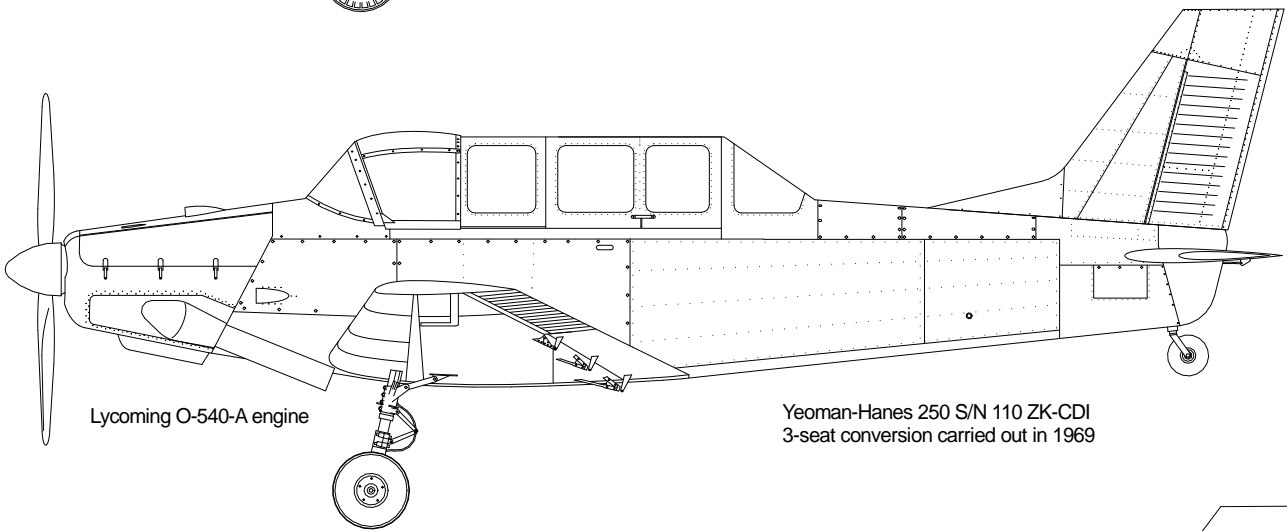

Lycoming O-540-A engine

Yeoman-Hanes 250 S/N 110 ZK-CDI 3-seat conversion carried out in 1969

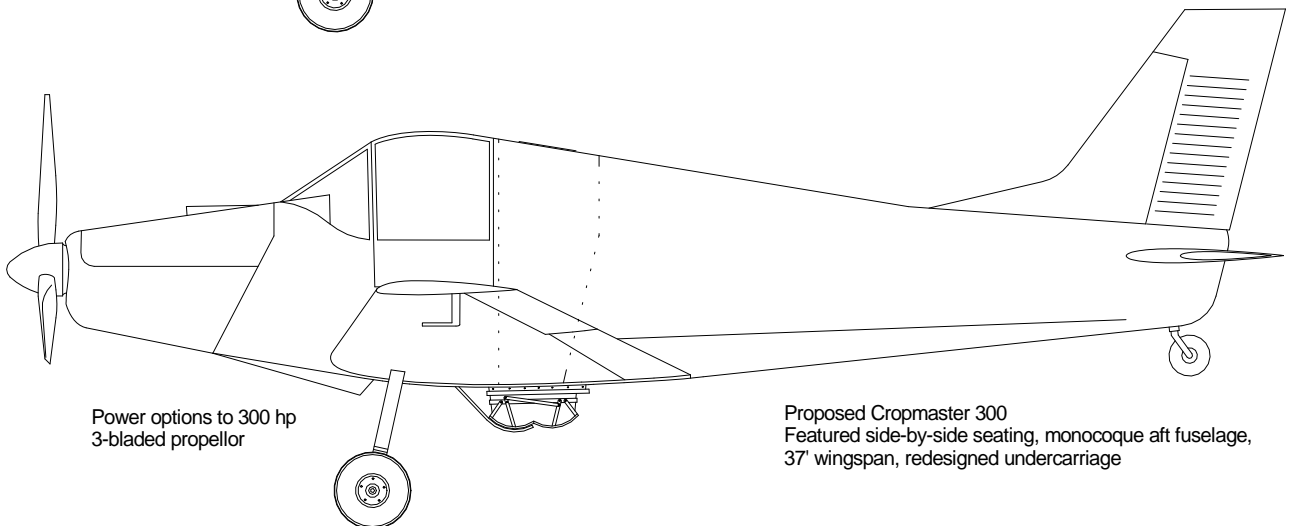

Power options to 300 hp 3-bladed propellor

Proposed Cropmaster 300 Featured side-by-side seating, monocoque aft fuselage, 37' wingspan, redesigned undercarriage

Yeoman Aviation YA-1 Cropmaster 250 and 250R 1959-69



Drawn by Derek Buckmaster 2003 for the DB Design Bureau website Plate 4 of 4

DRAFT ONLY

